

# CDMA/HDR: Rate-Based Slot Allocation

Natthapol Pongthaiapat

## Outlines

- Motivation
- CDMA/HDR (cdma2000 1xEV-DO)
- Throughput and Fairness Tradeoff
- Hard Bimodal Allocation
- Soft Multi-modal Allocation
- Throughput Analysis
- Simulation Results
- Conclusion

## Motivation



- Support High Data Rate users
- Rate Allocation is proportional to the channel condition (e.g., bases on the received SINR)
- Fairness Problem
  - low SINR users experience high latency

## CDMA/HDR (cdma2000 1xEV-DO)



- Provide variable data rates (forward link) through adaptive modulation and coding (multicodes) – Table 1.
- Use a combination of TDM and CDM on the forward link (only one active user on a slot) – figure 1.
- Higher data rate requires higher SINR – Table 2.

## CDMA/HDR (cdma2000 1xEV-DO)

Data rate (kb/s)	Packet length (bytes)	FEC rate (b/sym)	Modulation
38.4	128	1/4	QPSK
76.8	128	1/4	QPSK
102.6	128	1/4	QPSK
153.6	128	1/4	QPSK
204.8	128	1/4	QPSK
307.2	128	1/4	QPSK
614.4	128	1/4	QPSK
921.6	192	3/8	QPSK
1228.8	256	1/2	QPSK
1843.2	384	1/2	8PSK
2457.6	512	1/2	16QAM

Table 1: Various data rates [2]

## CDMA/HDR (cdma2000 1xEV-DO)

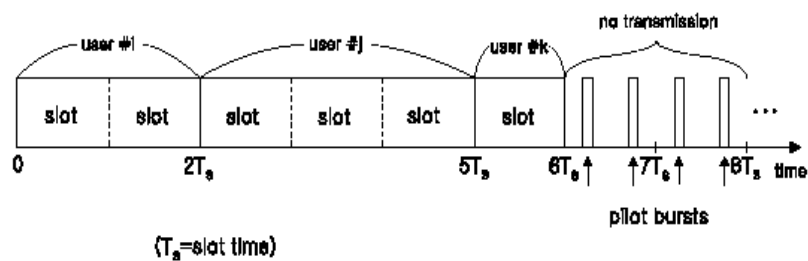

Figure 1: TDA-Packet downlink transmission where the pilot bursts are time multiplexed into the slot [1]

## CDMA/HDR (cdma2000 1xEV-DO)

Data rate (kb/s)	$E_c/N_t$ (dB)
38.4	-12.5
76.8	-9.5
102.6	-8.5
153.6	-6.5
204.8	-5.7
307.2	-4.0
614.4	-1.0
921.6	1.3
1228.8	3.0
1843.2	7.2
2457.6	9.5

**Table 2:** SNR for a 1 percent packet error rate [3]

## CDMA/HDR (cdma2000 1xEV-DO)

- Uses separate (non-overlapping spectrum) carrier to transmit HDR packets.
- A mobile measures the best pilot SINR from various base stations, uses the rate prediction based on Table 2, and makes a data rate request on DRC channel – figure 2.
- Data Rate request is proportional to the received SINR; DRC is updated as fast as at every 1.67 ms.
- Base station grants a higher priority to a mobile with higher SINR (get to transmit first with more slots if there are multiples data rate requests at the same time)

## CDMA/HDR (cdma2000 1xEV-DO)

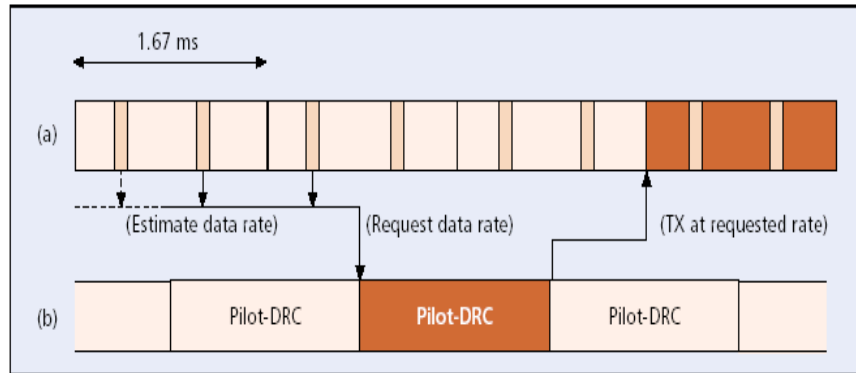

**Figure 2:** A channel estimation and data request channel timing diagram: a) access terminal; b) access terminal transmit [2]

## Throughput and Fairness Tradeoff

- Latency  $L_n$  is inversely proportional to the data rate  $R_n$
- Assume there are  $N$  user classes (data rates)
- Without fairness control, the average throughput is (b/s) [2],

$$R_{av} = \sum_{n=1}^N P_n R_n$$

- For instance,  $R_1 = 16$  kbps,  $R_2 = 64R_1 = 1,024$  kbps, transmission probability  $P_1 = P_2 = 0.5$ .  $R_{av} = 520$  kbps, but latency  $L_1/L_2 = 64$

## Throughput and Fairness Tradeoff

- Alternatively, if we allocate number of slots inversely proportional to the data rate,  $G_n = k/R_n$  ( $G_n$  is the number slots)
- Latency for all users is the same; the average throughput is [2],

$$R_{av} = \left( \sum_{n=1}^N P_n / R_n \right)^{-1}$$

- Using the same example,  $L_1 = L_2$  in this scheme, but  $R_{av} = 31.52$  kb/s (throughput is considerably dropped)
- Using bimodal and multimodal allocation to compromise throughput and fairness.

## Hard Bimodal Allocation

- Allow only two latency:  $L_{max}$  and  $L_{min}$
- If data rate is below the threshold  $C_{th}$ , its latency is set to  $L_{max}$ , otherwise =  $L_{min}$
- Define  $n_o$  such that  $R_n \leq C_{th}$  for  $n \leq n_o$ ; the slot allocation is,

$$G_n = k / [L_{max} R_n] \quad \text{if } n \leq n_o$$

$$G_n = k / [L_{min} R_n] \quad \text{otherwise}$$

## Hard Bimodal Allocation

- Hard Bimodal Throughput is,

$$C = \frac{\sum_{n=1}^{n_o} P_n + \sum_{n=n_o+1}^N \lambda P_n}{\sum_{n=1}^{n_o} P_n / R_n + \sum_{n=n_o+1}^N \lambda (P_n / R_n)}$$

- where  $\lambda = L_{\max} / L_{\min}$
- $C_{\text{th}}$  can be arbitrary value. In fact, in the analysis, we use  $C_{\text{th}}$  that maximize the above equation.

## Soft Multimodal Allocation

- Assign different latency to each user class [1]

$$L_m = L_1 \left[ \frac{(N-n)\lambda + (n-1)}{(N-1)\lambda} \right]$$

- Soft multimodal allocation throughput is [1],

$$C_s = \frac{p_1 + \sum_{n=2}^{N-1} P_n \frac{[(N-1)\lambda]}{[(N-n)\lambda + (n-1)]} + \lambda P_N}{P_1 / R_n + \sum_{n=2}^{N-1} (P_n / R_n) \frac{[(N-1)\lambda]}{[(N-n)\lambda + (n-1)]} + \lambda (P_N / R_N)}$$

## Throughput Analysis

- Throughput is a function of transmission probability  $P_n$
- $P_n$  is the probability that the best received SINR falls between the required SINR ( $= 2(E_b/I_o)_n$  in Table 2) for the requested data rate  $R_n$  and  $R_{n+1}$
- Determining  $P_n$  is not straightforward

## Throughput Analysis

- Analytical Evaluation of  $P_n$  [1]
  - Select randomly the location of each user in each sector (3 sectors)
  - Determine  $SINR_{max}$  given the requested  $R_n$  of each user in all sectors
  - Test that the selected  $SINR_{max}$  of each user in each sector whether it satisfies its  $(E_b/I_o)_n$  requirement or not.
  - Repeat the above steps for all combinations of  $R_n$  of each users in all sectors.
  - Count the relative frequency that the feasibility test of each user in all sectors has passed the  $SINR_{max}$  test
- Calculate the joint probability of each transmission rate  $R_n$  in 3 sectors
- Determine the transmission probability  $P_n$  correspondingly

## Throughput Analysis

- Alternatively,  $P_n$  can be determined by the  $E_b/I_o$  (SINR) distribution measured in field trial.

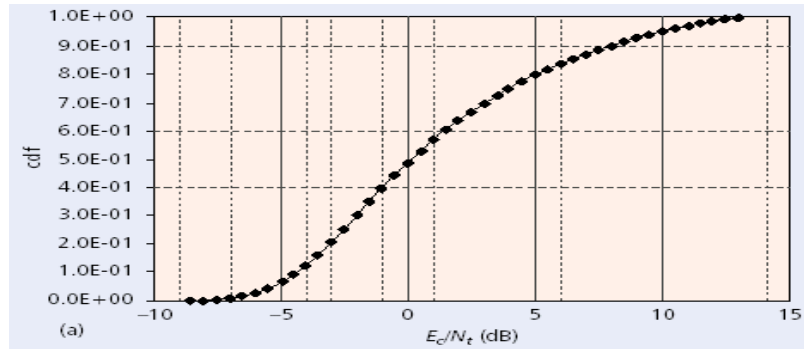

**Figure 3:**  $E_b/I_o$  distribution for a typical embedded sector in a 3 sector network [2]

## Throughput Analysis

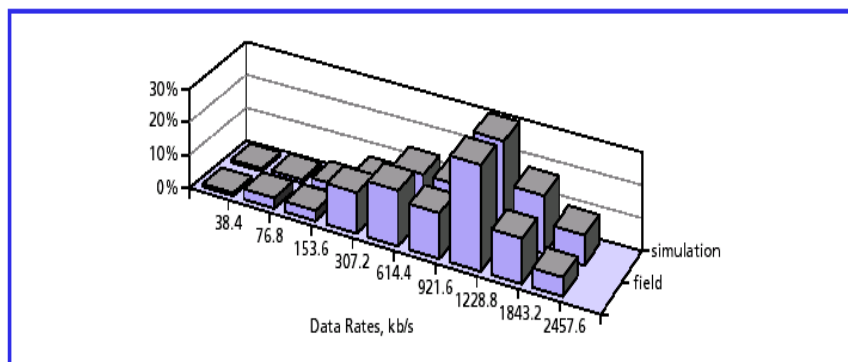

**Figure 4:** Comparison of the forward link rate request distributions measured in the field and obtained using simulation [3]

## Simulation Results

- Hard Bimodal Throughput

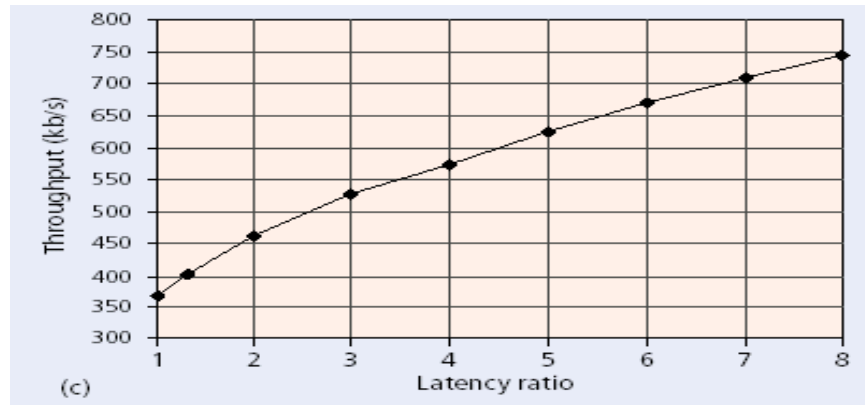

Figure 5: sector throughput vs. latency ratio  $L_{\max}/L_{\min}$  [2]

## Simulation Results

- Multimodal latency is compromised compared to Bimodal latency -- Table 3.
- Multimodal sacrifices a modest loss in throughput with a considerable gain in fairness – Figure 6.

WAITING TIME DISTRIBUTION ( $\mathcal{L}_m$ ) FOR AN 87% USER POPULATION UNDER THE HARD AND SOFT LATENCY ALLOCATION, GIVEN THE IMPERFECT CANCELLATION  $\nu = 0.1$  AND THE LATENCY RATIO  $\lambda = 8$

Rate	$p_m$	$\mathcal{L}_m$ (Hard Alloc.)	$\mathcal{L}_m$ (Soft Alloc.)
$m = 5$	0.46	$8\mathcal{L}_{\min}$	$4\mathcal{L}_{\min}$
$m = 6$	0.41	$\mathcal{L}_{\min}$	$3\mathcal{L}_{\min}$

Table 3: Latency Comparison [1]

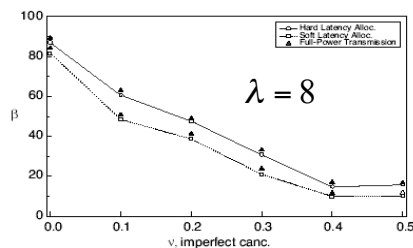

Figure 6: Throughput Comparison [1]

## Conclusion

- cdma2000 achieves downlink HDR performance through adaptive modulations and codings.
- Data rate is proportional to the channel condition
- Compromise throughput and latency using bimodal and multimodal slot allocations.
- Satisfy different BER requirements.
- Neglect other QoS parameters for different traffic classes such as delay, packet loss: no specific slot scheduling.
- Consider only number of slots allocation in order to achieve the desire throughput and latency.

## References

- [1] D. I. Kim, "Optimum Packet Data Transmission in Cellular Multirate CDMA Systems With Rate-Based Slot Allocation," *IEEE Transactions on Wireless Communications*, vol. 3, no. 1, Jan. 2004
- [2] P. Bender, et. al., "CDMA/HDR: A Bandwidth-Efficient High-Speed Wireless Data Service for Nomadic Users," *IEEE Communications Magazine*, July 2002
- [3] Q. Bi, et. al., "Performance of 1xEV-DO Third-Generation Wireless High-Speed Data Systems," *Bell Labs Technical Journal* 7(3), 97-107, 2003