



Microsystems Research

Dr. Qing-Ming Wang

Department of Mechanical Engineering
University of Pittsburgh

Department of Mechanical Engineering



Current Research Activities in MEMS/Transducer Lab

- ◆ **Proton Exchange Membrane (PEM) Fuel Cells:**
 - Hydrogen as fuel
 - Directly use methanol as fuel (DMFC)
- ◆ **Applications**
 - Mobile applications
 - Miniaturized fuel cell for portable electronics applications
- ◆ **Research issues**
 - The engineering fundamentals behind each functional component in the PEM fuel cells
 - Fuel cell design and fabrication
 - Fuel cell modeling
- ◆ **Goals:**
 - Optimal design and low cost fabrication
 - Performance improvement

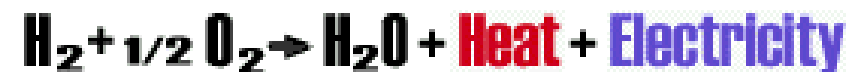
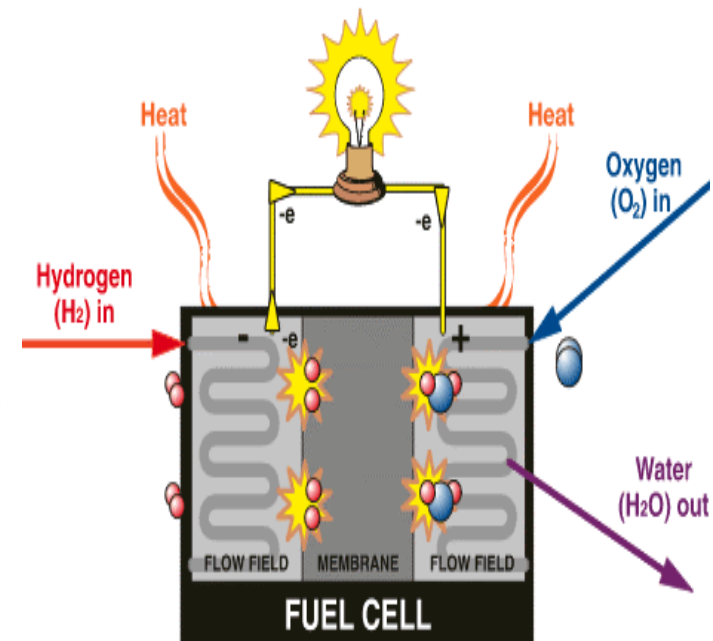

Current Research Activities in MEMS/Transducer Lab



- ◆ Proton Exchange Membrane (PEM) Fuel Cells
- ◆ Research Projects:
 - **Micro PEM Fuel Cells for Portable Electronics**
 - » Supported by Pittsburgh Digital Greenhouse
(09/01/2001-----)
 - **Other Supports: NSF, DOE**
- ◆ Research Collaborators
 - Faculty
 - Dr. Minking Chyu Dr. Qing-Ming Wang
 - Dr. Laura Shaefer Dr. Scott Mao
 - Students and Post-docs
 - Tao Zhang, etc.: Fuel cell design, fabrication ,test, modeling.
 - One post-doc is coming (12/01/01): Fuel cell fabrication & modeling

Current Research Activities in MEMS/Transducer Lab



◆ Piezoelectric MEMS devices

- Processing research of thin/thick films of piezoelectric materials such as PZT
- Design and microfabrication of various piezoelectric MEMS devices

◆ Current Research Topics:

- Thick film PZT deposition
- PZT-on-Si microsensors and microactuators
 - » Micropumps
 - » Microvalves
 - » Force sensor arrays
 - » Piezoelectric power generation devices
 - » Microactuator array for high speed ink jet printing
- Micro-devices using electro-active polymers

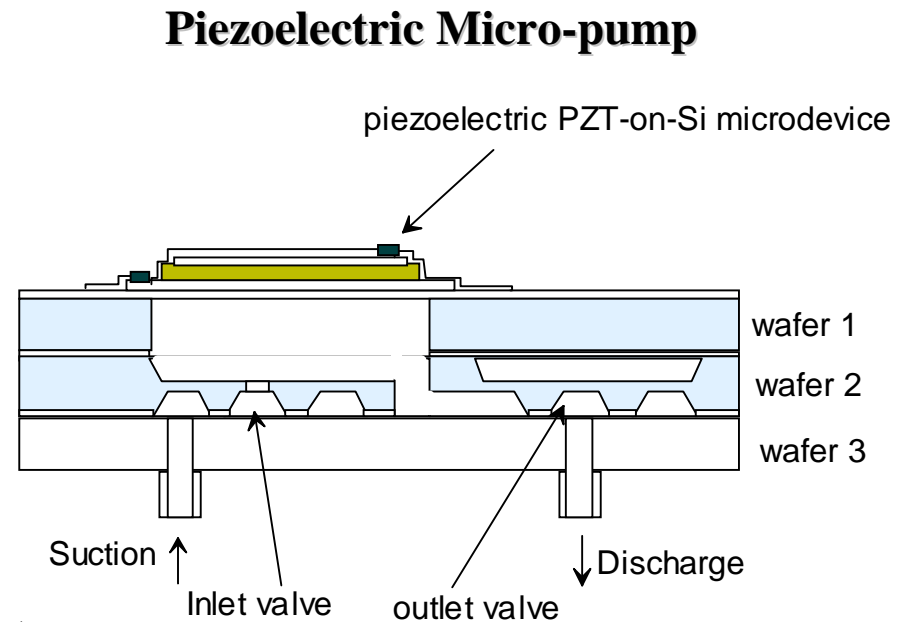

Current Research Activities in MEMS/Transducer Lab



◆ Research activities on transducers also include:

- Piezoelectric actuators for fuel injection apparatus of direct gasoline-injection engines, and diesel engines
- Compact Piezoelectric Transformers
 - Both step-up & step down types
- Piezoelectric Micro-Actuators for hard disk drives(HDDs)
- Compact Piezoelectric Ultrasonic Motors

◆ Research issues:

- Design and fabrication of piezoelectric actuators
- Dynamic characterization of actuator devices
- Heat generation and reliability

Current Research Activities in MEMS/Transducer Lab



- ◆ **Piezoelectric MEMS and Transducers Research**
- ◆ **Projects:**
 - **Thin/Thick film PZT microdevices for MEMS applications**
 - » **University Internal Small Grants (07/01/01 ---06/30/03)**
 - **Other Supports:**
 - Pittsburgh Digital Greenhouse (PDG), NSF, DARPA, ONR**
- ◆ **Research Collaborators**
 - **Faculty**
 - Dr. William W. Clark** **Dr. Jeffrey S. Vipperman**
 - **Students**
 - Qingming Chen, etc.**

Current Research Activities in MEMS/Transducer Lab



- ◆ **Piezoelectric MEMS and Transducers Research**

- ◆ **Investigators**

- **Faculty**

- Dr. Qing-Ming Wang**

- Dr. William W. Clark**

- Dr. Jeffrey S. Vipperman**

- **Students**

- Qingming Chen**

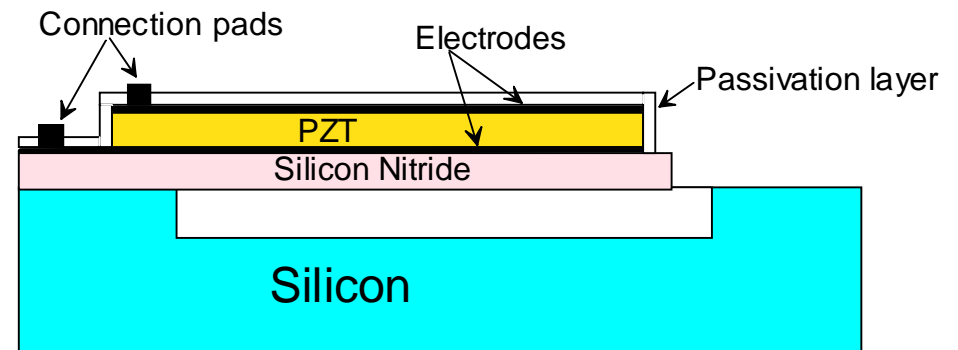

Piezoelectric PZT-on-Si
cantilever resonator