

Hydration of single crystals of dipalmitoylphosphatidylcholine

(optical birefringence/x-ray diffraction/liquid crystals)

TETSUO URABE*, SANFORD A. ASHER†, AND P. S. PERSHAN

Division of Applied Sciences, Harvard University, Cambridge, Massachusetts 02138

Communicated by Nicolas Bloembergen, April 13, 1981

ABSTRACT Optical birefringence and x-ray measurements are reported for single crystals ($0.5 \text{ mm} \times 2 \text{ mm} \times 5 \text{ }\mu\text{m}$) of dipalmitoylphosphatidylcholine as a function of temperature and relative humidity. Large single crystals grown in CHCl_3 /acetone at a low water concentration undergo an irreversible phase transformation at 20°C and 70% relative humidity or at 60°C and 65% relative humidity. After this transformation occurs, the crystals can be made to undergo a reversible transformation into and out of the L_α phase. The x-ray-determined mosaic spread in the hydrated crystal is less than $\approx 0.04^\circ$ both above and below the main transition.

A number of different approaches have been made to prepare oriented lecithin/water samples without ever obtaining the same degree of alignment in high-water samples that can be obtained in low-water single crystals (1-9). In this manuscript, we describe optical and x-ray measurements on monodomain single-crystal samples of dipalmitoylphosphatidylcholine ($\text{Pam}_2\text{PtdCho}$) that have a mosaic spread of $<0.04^\circ$ at different temperatures and water contents. They were obtained by exposing crystals grown from an acetone/chloroform solution containing $<0.5\%$ water at $\approx 16^\circ\text{C}$ to relative humidities of up to 95% and temperatures up to 75°C . Optical and x-ray studies of the as-grown crystals are described elsewhere (10).

X-ray diffraction studies of lecithin/water phases have been carried out by a number of workers (11-22), and the general properties of the phase diagrams are well established. There exists a transition temperature T_c (see, for example, ref. 12) that is a monotonically decreasing function of water content such that, for $T > T_c$, the equilibrium phase consists of planar arrays of "fluid bilayers." This is classified as the L_α phase in the lipid literature and as a smectic A phase in the liquid crystal literature (23). For $T < T_c$ and low water concentrations, the equilibrium phases are crystalline—i.e., periodic in three dimensions. At higher water concentrations, for $T < T_c$, x-ray diffraction measurements on partially oriented samples indicate rows of scattering along the (h, O, l) axis, $h \approx (4.2 \text{ \AA})^{-1}$, suggestive of phases that have well-developed periodicity within each bilayer but in which successive bilayers are not correlated (19, 20). Thus, these phases can be simply interpreted as two-dimensional crystals stacked on top of one another but without any correlation in their relative positions. Although phases with these properties have been discussed in the liquid crystal literature, it is now generally agreed that, if such phases do exist, the periodicity within the bilayer must have a finite correlation length (24, 25). This would result in Bragg-like peaks that have shapes different from those of true Bragg peaks from three-dimensional crystals.

Attempts have been made to observe this phenomenon in thermotropic liquid crystals by using high-resolution x-ray dif-

fraction techniques on well-oriented monodomain samples. In one case, a system previously believed to have this property was shown instead to be a three-dimensional crystal in which the layer positions are correlated (26, 27). In a second case, the molecular positions in separate layers did appear uncorrelated, although the bond orientations were locked together (28). This system had hexagonal symmetry and the six peaks observed by x-ray diffraction were broadened by finite correlation lengths. This new thermodynamic phase had not been observed previously and is under active study. Thus, it is particularly important to determine the precise nature of lipid/water phases for $T < T_c$, to determine the extent of interlayer correlations and, if they belong to this new class, to compare their measured properties with the predicted ones. Based on previous work done on thermotropic liquid crystals, these studies will require well-oriented monodomain samples at $T < T_c$ and different water concentrations (29).

Well-oriented monodomain samples would also be important for x-ray studies of fundamental properties of the lipid/water systems for $T > T_c$. For example, the low angle (O, O, l) x-ray peaks that result from the lamellae structure are predicted to have characteristic shapes different from that of a true crystal Bragg peak (23, 30). Some features of this prediction have been tested on thermotropic liquid crystals, but difficulties in obtaining samples in which the mosaic spread is sufficiently small have limited the measurements (31). The samples we describe below have a mosaic spread that is smaller than the resolution of our x-ray apparatus—i.e., $\approx 0.04^\circ$ —and would be particularly useful for this measurement. From the shape of the Bragg-like peak, it is possible to extract values of the elastic constant B for layer compression and the K for layer curvature (23, 30, 31). These have never been adequately measured for any lipid/water system.

OPTICAL HYDRATION STUDIES

Birefringent single crystals ($1 \text{ mm} \times 4 \text{ mm} \times 5 \text{ }\mu\text{m}$) of $\text{Pam}_2\text{PtdCho}$ were grown from CHCl_3 /acetone, 3:2 (vol/vol) as described (10). At room temperature, these crystals are insensitive to relative humidities (RH) below $\approx 68\%$. Fig. 1A shows a crystal as viewed between crossed polarizers after 1 day at 68% RH and room temperature. The polarizer-analyzer axes are at 45° to the long axis of the crystal. The bright areas result from the crystal biaxiality that can be associated with molecular tilt (10). In contrast, near the edges, and elsewhere, small dark sections of reduced biaxiality occur. Fig. 1B shows the same crystal after 6 days at 68% RH and, after 1 day at 80% RH, one obtains the crystal shown in Fig. 1C. This crystal is essentially

Abbreviations: $\text{Pam}_2\text{PtdCho}$, dipalmitoylphosphatidylcholine; RH, relative humidity.

* Permanent address: Sony Corporation, 6-7-35 Kitashinagawa, Shinagawa, Tokyo, Japan.

† Present address: Department of Chemistry, University of Pittsburgh, Pittsburgh, PA 15260.

The publication costs of this article were defrayed in part by page charge payment. This article must therefore be hereby marked "advertisement" in accordance with 18 U. S. C. §1734 solely to indicate this fact.

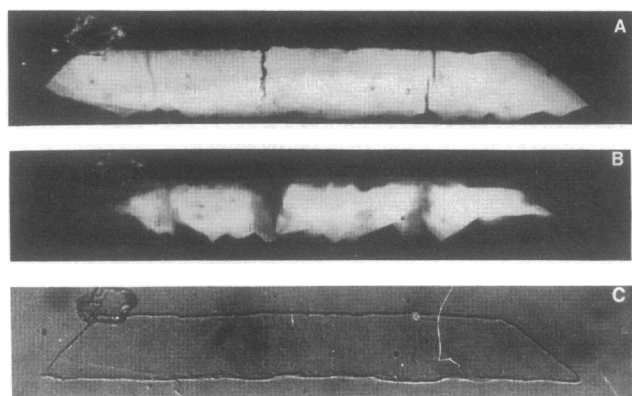

FIG. 1. Hydration stages of a Pam₂PtdCho crystal (0.2 mm × 5 μm) exposed to 65% RH. (A) After ≈1 day at $T = 20^{\circ}\text{C}$, viewed between crossed polarizers oriented $\approx 45^{\circ}$ to the long axis of the crystal. (B) After 6 days under the same conditions. (C) Same crystal as in B after 1 day at 80% RH. The polarizers are uncrossed slightly to make the crystal visible.

uniaxial and, as it is not visible between crossed polarizers, the picture was taken with the polarizers slightly uncrossed. Presumably the effect of hydration is to eliminate the large molecular tilt previously demonstrated for the as-grown crystals (10).

A more quantitative measure of this effect was made by using a focused He/Ne laser and a Soleil-Babinet compensator to measure the optical path difference [$\Delta n \times d$ ($d \approx 5 \mu\text{m}$)] between light polarized along the fast and slow optical axes. These coincide with the long and short crystal dimensions, respectively. Fig. 2 shows the results for $T \approx 25^{\circ}\text{C}$ and various RH. The RH was determined from solutions of sulfuric acid at different concentrations that were independently calibrated by measuring the vapor pressure of water above the solutions. Successive points were taken at intervals of ≈ 1 day. At RH $\leq 65\%$, there were no detectable changes, even at the edges of the crystal, while at RH $\geq 70\%$, the crystals appeared uniformly hydrated after 1 day. The hydration at $\approx 70\%$ RH appears irreversible; overnight pumping of the crystals at room temperature does not restore the birefringence.

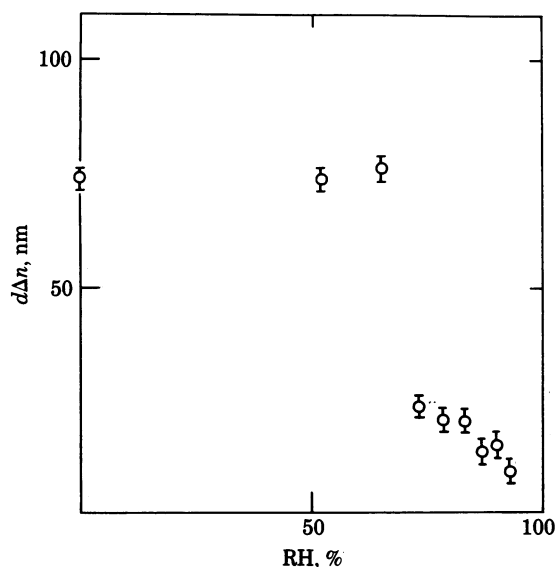

FIG. 2. Optical path difference between He/Ne laser light polarized along the long and short axes of a Pam₂PtdCho single crystal at 25°C .

X-RAY HYDRATION STUDIES

The effects of hydration can also be monitored by x-ray diffraction. To increase the signal intensity, three or four single crystals are mounted on a glass slide with their thin dimensions normal to the surface of the slide. The slide is placed in a sealed oven mounted on a goniometer. The oven is connected to a separate chamber, maintained at room temperature, containing the H_2SO_4 solution that controls the RH. The oven is mounted on a General Electric XRD5 x-ray diffractometer and (O, O, l) Bragg peaks from the long spacing are observed in reflection. The measurements were made with $\text{CrK}\alpha$ radiation, $\lambda = 2.291 \text{ \AA}$ at 45 kV and 14 mA. The results are shown in Fig. 3A. The points were measured at 1-day intervals in the sequence indicated by the numbers. As in the optical studies, at RH $\leq 70\%$, no observable change occurs, while, at RH $> 70\%$, there is a dramatic increase in the long spacing (from $\approx 49.3 \text{ \AA}$ to 58.6 \AA). Further increases in RH cause the long spacing to increase gradually to 61 \AA . The reversibility of the hydration was examined following the measurement of point 8 by exposing the sample to pure H_2SO_4 overnight. Point 9 resulted, and points 10–13 resulted from further hydration.

It should be noted that after the primary transformation at RH $\approx 70\%$, the crystals appeared to exchange water with their environment rapidly. For example, each time the oven was opened to the room atmosphere to change the H_2SO_4 solution, rapid changes in the long spacing could be observed. On sealing the oven containing a new solution, the spacings would recover over several hours. Presumably this is the length of time it takes for the vapor pressure in the oven to come to equilibrium with the H_2SO_4 solution. The wait of 1 day between points was chosen to ensure this equilibrium.

These results can be compared with the results of others by using Elworthy's data relating absorbed water to RH (32, 33) (Fig. 3B). In general, the agreement is reasonably good; however, there are discrepancies of $\approx 2\%$.

The uncertainties in our values for the long spacing can be estimated from the diffractometer geometry illustrated in Fig. 4. As the angular spread of the incident beam ($\delta\theta_s$) is much larger than the resolution of the detector ($\delta\theta_D$), the width of Bragg peaks for both ($\theta, 2\theta$) and ω scans are determined by the $250\text{-}\mu\text{m}$ exit slit and the projected crystal length. For typical crystals 2 mm long, the angular width of the detector $\delta\theta_D \leq (0.250 + 2\sin\theta_D)/100$ radians or $(0.14 + 1.14\sin\theta_D)^{\circ}$. For the first-order $\theta_D \approx 1.15^{\circ}$, $(\delta\theta_D)_{1st} \leq 0.16^{\circ}$, and for the fourth-order $(\delta\theta_D)_{4th} \leq 0.24^{\circ}$. As the peak position can be reproducibly read to $\approx 1/5$ of the full width at half-maximum, the uncertainty in long spacing, d , due to spectrometer resolution is $\delta d/d \leq [0.24/(4 \times 1.14)] \times 1/5$ or $\approx 1.0\%$. We claim that this is the uncertainty in relative measurements for any set of scans in which the crystal is not moved. A more serious source of error for the absolute value of d is the positioning of the crystal at the center of the diffraction circle. For example, if the crystal is displaced from the center of the diffraction circle by $\approx 1 \text{ mm}$ parallel to the surface of the glass side, the error in long spacing could be $\approx 2\%$.

The temperature dependence of the hydration effects was examined by first exposing the as-grown crystals to 52% RH overnight. Then, the temperature was raised in steps of 2°C , and the long spacing was measured every 30 min. The results are shown in Fig. 5. For $T \leq 58^{\circ}\text{C}$, the long spacing increases very slowly with increasing temperature, from 49.2 \AA to 49.4 \AA (phase I). At 58°C , however, there is a sudden increase to 54.5 \AA , corresponding to what we believe to be a transition to an L_a or smectic A phase (phase III). Elworthy's results (32, 33) indicate that 58% RH corresponds to $\approx 8\%$ water (wt/wt), and the

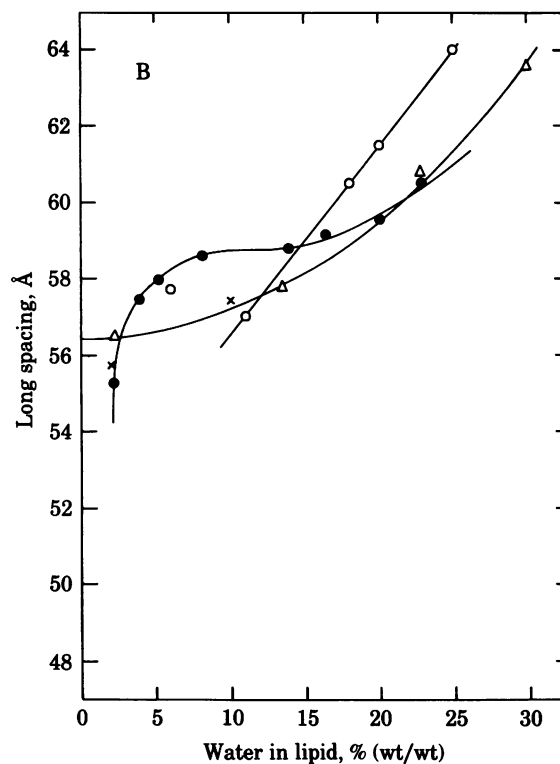
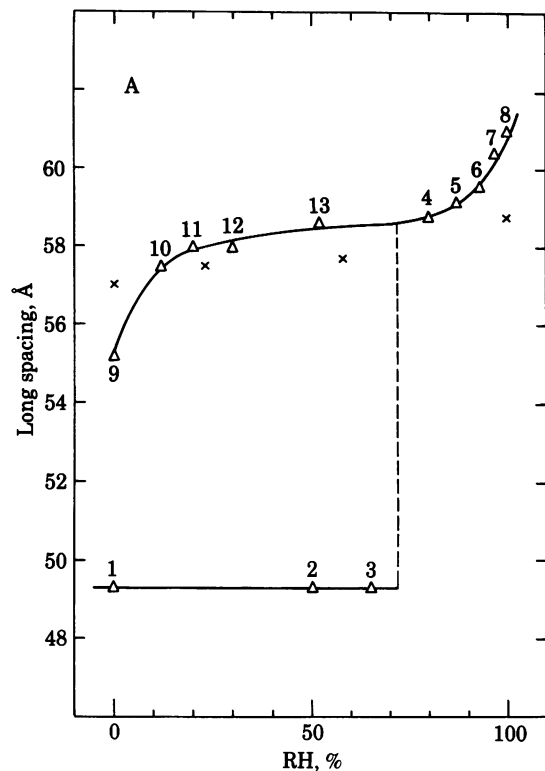

FIG. 3. X-ray measurements of the hydration of a Pam₂PtdCho crystal at 20°C. (A) Long spacing as a function of relative humidity. Points (Δ) were recorded in the sequence indicated. \times indicates data by Torbet and Wilkins (22). (B) Same data as in A expressed in terms of weight percent of absorbed water by using Elworthy's (32, 33) measured relationship to RH. \bullet , our data; \circ , Tardieu *et al.* (14); Δ , Chapman *et al.* (13); \times , Stamatoff *et al.* (19). We assume that overnight exposure to pure H₂SO₄ produces the monohydrate.

optically measured phase diagram of Powers and Pershan (9) indicates that the phase transition temperature T_c for this water content is $\approx 60^\circ\text{C}$. There is no evidence for any further phase

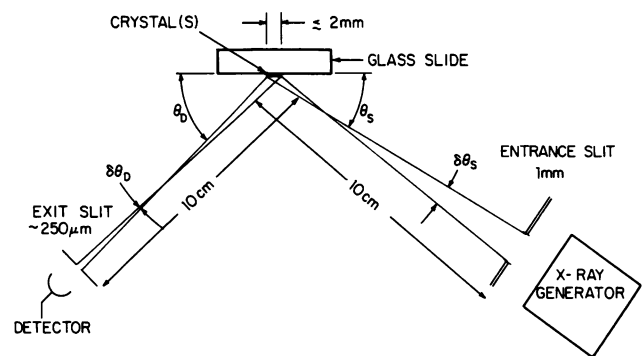

FIG. 4. Schematic of the x-ray diffractometer. For $(\theta, 2\theta)$ scans, $\theta = \theta_s = \theta_D$. For ω scans, $\theta_s + \theta_D$ is held fixed and $\omega = (\theta_s - \theta_D)/2$.

transformation up to the maximum temperature that we reached, 78°C .

This crystal was then cooled to 20°C , where its long spacing increased to 58.0 \AA (phase II). This value is within 1% of the 58.6 \AA obtained earlier in the hydration study at a fixed temperature (Fig. 3) for a different crystal. On subsequent heating, the long spacing decreases slowly until, at $\approx 50^\circ\text{C}$, the peak splits into two peaks: one corresponding to the lower temperature phase II value of $\approx 57 \text{ \AA}$ and the second to the higher temperature phase III value of $\approx 55 \text{ \AA}$. This could signify coexistence between two phases except that once the chemical potential for water is fixed by equilibrium at a given RH, the phase rule specifies that for a two-component system at a fixed pressure, coexistence between two phases can occur at only one temperature value. This is in contrast to studies in which the chemical potential for water is not fixed and for which coexistence occurs over a range of temperature. Thus, either the system is not a true two-component system or the coexistence is not in thermal equilibrium. We believe the latter, since after

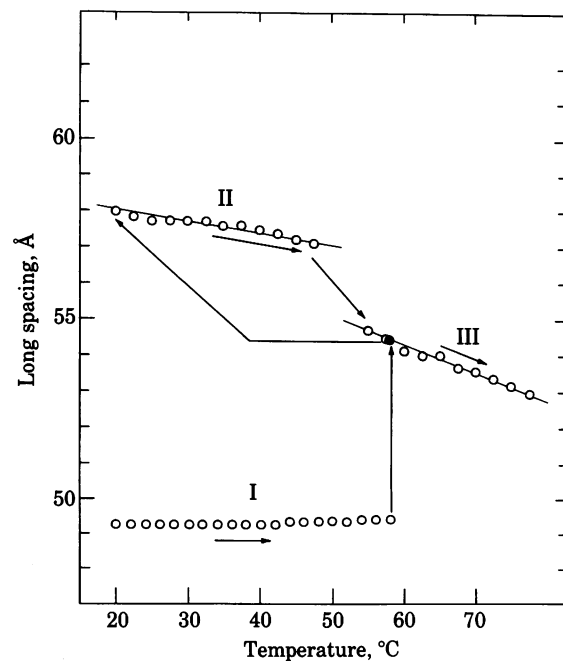

FIG. 5. Temperature dependence of the long spacing of a Pam₂PtdCho crystal hydrated at 52% RH. Arrows indicate sequence in which the measurements were made. After the point indicated by the solid circle was measured, the sample was maintained overnight at 20°C .

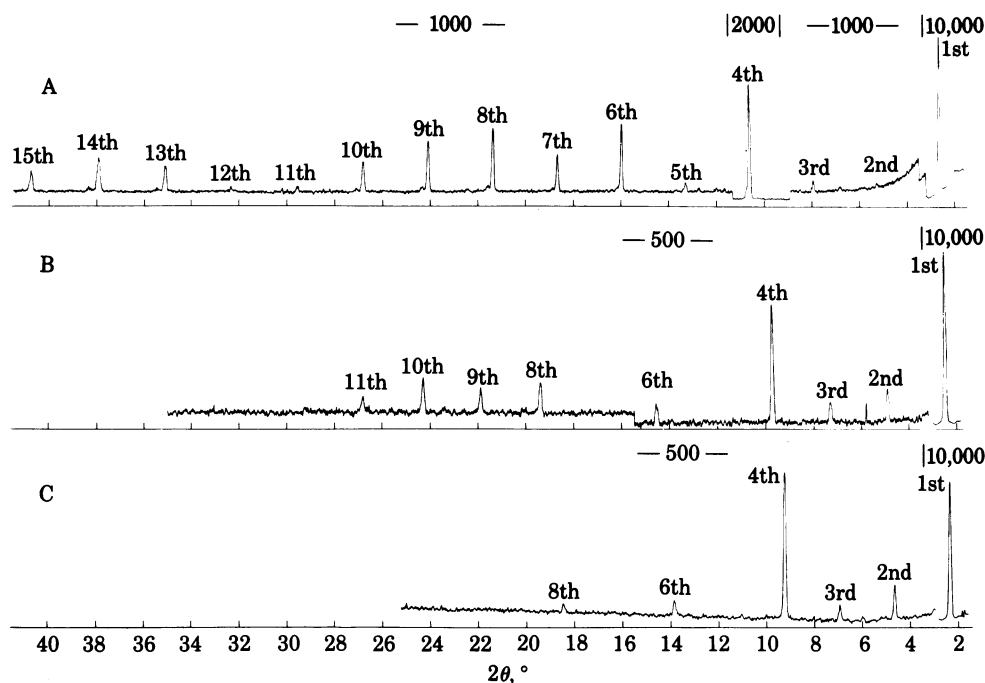

FIG. 6. $(\theta, 2\theta)$ scans of as-grown crystals (A), crystals hydrated at 65% RH and 60°C (B), and the crystal in B after being cooled to 20°C (C). The full-scale range in cps and the order of the Bragg peaks are indicated.

sitting at one temperature for several hours, the relative intensities of the two peaks changed. Furthermore, thin-layer chromatography was not able to detect even trace amounts of any component other than Palm₂PtdCho. This is a point that should be examined further. Further heating produces the smaller value for the long spacing previously found for phase III at 58.8°C.

To investigate the mosaic spread of the hydrated phases, a fresh crystal was equilibrated overnight at 65% RH and 65°C. From the $(\theta, 2\theta)$ scans for the as-grown (phase I) and the hydrated crystals (phase III) shown in Fig. 6 A and B, one can see that in addition to a change in long spacing, the relative intensities of the different orders are significantly altered, emphasizing the fact that there has been a phase transformation. As discussed above, the effect of the large angular spread of the incident radiation, $\approx 0.6^\circ$, is that the resolution of a $(\theta, 2\theta)$ scan is effectively the convolution of the mosaic spread and the angular resolution of the detector, $\approx 0.16^\circ$ and 0.24° for the first and fourth orders respectively for a sample ≈ 2 mm long. Values for smaller crystals are smaller. It is clear that both spectra are essentially resolution limited, implying a mosaic spread of less than $\approx 0.04^\circ$ for the phase III sample. To confirm this, compare the ω scans, in which the detector, $\theta_s + \theta_D$, is held at the angle appropriate to the first-order peak and the crystal, $\omega = \theta_s - \theta_D$, is rotated (Fig. 7 A and B). The full widths at half-maximum are 0.07° and 0.06° for the as-grown and the hydrated crystal, respectively (crystals smaller than 2 mm). Figs. 6C and 7C show similar scans for the crystal that was in phase III after cooling it to 20°C. Presumably, this is now in phase II; from Fig. 6C, it is clearly in a different phase from the other two. Again, this scan and that in Fig. 7C are resolution limited, indicating mosaic spreads of less than $\approx 0.04^\circ$. Curiously, the lattice spacing for this crystal is 57.3 Å or 1–1.5 Å less than the values expected from the hydration measurements shown in Fig. 3. This suggests that there may be some hysteresis effect in heating up to and cooling down from phase III.

In conclusion, we have demonstrated that the relatively large, easily grown crystals that Asher *et al.* have described (10)

can be hydrated and heated to obtain samples that have mosaic spreads of $< 0.04^\circ$ in the L_α or smectic A phase, as well as for hydrated phases at $< T_c$.

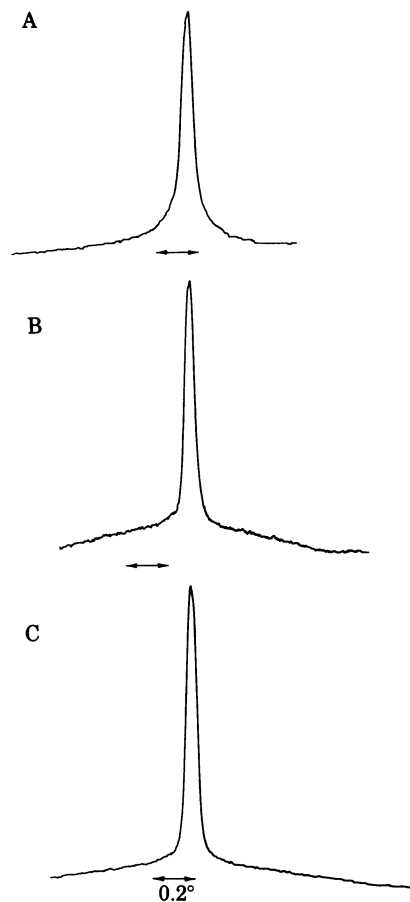

FIG. 7. ω scans through the first-order peak for the same crystals as in Fig. 6. Full scale is 10,000 cps.

We are indebted to Frank Molea for assistance in the x-ray diffraction measurements. This work was sponsored in part by the National Institutes of Health under Grant GM-24081-02, the National Science Foundation under Grant DMR-79-23597, and the Joint Services Electronics Program (U.S. Army, Navy, and Air Force) under Contract N00014-75-C-0648.

1. Levine, Y. K. & Wilkins, M. H. F. (1971) *Nature (London) New Biol.* **230**, 69-72.
2. Levine, Y. K., Bailey, A. I. & Wilkins, M. H. F. (1968) *Nature (London)* **220**, 577-578.
3. Libertini, L. J., Waggoner, A. S., Jost, P. C. & Griffith, O. H. (1969) *Proc. Natl. Acad. Sci. USA* **64**, 13-19.
4. Jost, P., Libertini, L. J., Hebert, J. C. & Griffith, O. H. (1971) *J. Mol. Biol.* **59**, 77-98.
5. Hsia, J.-C., Schneider, H. & Smith, I. C. P. (1970) *Biochim. Biophys. Acta* **202**, 399-402.
6. Powers, L. & Clark, N. A. (1975) *Proc. Natl. Acad. Sci. USA* **72**, 840-843.
7. Asher, S. A. & Pershan, P. S. (1979) *Biophys. J.* **27**, 393-421.
8. Asher, S. A. & Pershan, P. S. (1979) *J. Phys. (Paris)* **40**, 161-173.
9. Powers, L. & Pershan, P. S. (1977) *Biophys. J.* **20**, 137-152.
10. Asher, S. A., Sterns, R., Urabe, T. & Pershan, P. S. (1980) *Mol. Cryst. Liq. Cryst.* **59**.
11. Luzzati, V. (1968) *Biological Membranes*, ed. Chapman, D. (Academic, New York), p. 71.
12. Chapman, D. (1975) *Q. Rev. Biophys.* **8**, 185-236.
13. Chapman, D., Williams, R. M. & Ladbroke, B. D. (1967) *Chem. Phys. Lipids* **1**, 445-475.
14. Tardieu, A., Luzzati, V. & Reman, F. C. (1973) *J. Mol. Biol.* **75**, 711-733.
15. Levine, Y. K. (1972) *Prog. Biophys.* **15**, 3-74.
16. Janiak, M. J., Small, D. M. & Shipley, G. G. (1979) *J. Biol. Chem.* **254**, 6068-6078.
17. Albon, N. (1976) *J. Cryst. Growth* **35**, 105-109.
18. Pearson, R. H. & Pasher, I. (1979) *Nature (London)* **281**, 499-501.
19. Stamatoff, J. B., Graddick, W. F., Powers, L. & Moncton, D. E. (1979) *Biophys. J.* **25**, 253-262.
20. Hentschel, M., Hosemann, R. & Helfrich, W. (1980) *Z. Naturforsch. A* **35**, 659-660.
21. Small, D. M. (1967) *J. Lipid Res.* **8**, 551-557.
22. Torbet, J. & Wilkins, M. H. F. (1976) *J. Theor. Biol.* **62**, 447-458.
23. De Gennes, P. G. (1975) *The Physics of Liquid Crystals* (Clarendon, Oxford).
24. Birgeneau, R. J. & Litster, J. D. (1978) *J. Phys. (Paris) Lett.* **39**, 399-402.
25. Nelson, D. R. & Halperin, B. I. (1979) *Phys. Rev. B* **19**, 2457-2484.
26. Pershan, P. S., Aeppli, G., Litster, J. D. & Birgeneau, R. J. (1981) *Mol. Cryst. Liq. Cryst.*, in press.
27. Moncton, D. E. & Pindak, R. (1979) *Phys. Rev. Lett.* **43**, 701-703.
28. Moncton, D. E. & Pindak, R. (1980) in *Ordering in Two Dimensions*, ed. Sinha, S. (North-Holland, New York), pp. 83-90.
29. Doniach, S. (1980) in *Ordering in Two Dimensions*, ed. Sinha, S. (North-Holland, New York), pp. 67-72.
30. Caille, A. (1972) *C.R. Hebd. Seances Acad. Sci. Ser. B* **274**, 891-893.
31. Als-Nielsen, J., Birgeneau, R. J., Kaplan, M., Litster, J. D. & Safinya, C. R. (1977) *Phys. Rev. Lett.* **39**, 1668-1670.
32. Elworthy, P. H. (1961) *J. Chem. Soc.* 5385-5389.
33. Elworthy, P. H. (1962) *J. Chem. Soc.* 4897-4900.